



Designed Network Solutions

# DAV - P - C Product Catalogue



Air release & Vacuum  
Break Valves

---

Compliant to EN1074-4  
WRAS Approved No.1709307

### DAV-P-KA

This valve has been designed for efficient discharge and intake of air in water transport systems, filtering systems, containers, and other places where confined air could impair the system's operation.

The valve is appropriate for:

- Expelling the air at high flow velocity during the initial filling of the systems
- Introducing large quantities of air when the pipe drains, maintaining atmospheric pressures in the pipe and preventing collapse and cavitation damage to the conduits
- Relieving the entrained air from the water, while the network is pressurized

### Properties:

Leak-proof sealing at all conditions, including low system pressure. The aerodynamic design of the float provides air flow at a very high velocity. The float does not close before the water has reached the valve. Threaded outlet elbow allows various possibilities of drain connection. The valve design contains a very limited number of parts, allowing an easy dismantling for maintenance.

### Operation:

The DAV-P-2-KA valve has three modes of operation: Discharge of large quantities of air at a high flow velocity when the conduit is being filled. When the water arrives at the valve, the main float rises up and closes the outlet. Introduction of air into the pipeline when the internal pressure is sub-atmospheric. The pressure difference forces the main float to drop to "opened" position, allowing the air to flow into the pipe. Releasing entrained air from the pipeline. Small quantities of diluted air accumulate in high peaks of the pipeline and in the peak of the valve. The pressurized air expels the water. The descending water



level moves the main float with it. At a certain position the main float pulls down the small seal, that partially opens the nozzle. The pressurized air can escape, the water level rises and the nozzle re-closes.

### Technical Specifications

- Operating pressure of 0.2 to 16 bars
- 1/2", 3/4", 1", 2" BSP or NPT threaded base - as per the customer's choice
- Structure materials: Cover: GRP (UV resistant), Base: GRP or Brass
- Internal parts: corrosion resistant plastic materials and synthetic rubber
- The valve allows the discharge of 700m<sup>3</sup>/<sub>h</sub> of air at pipe pressure of 0.5 bar, when fully-open

### Principle of operation:

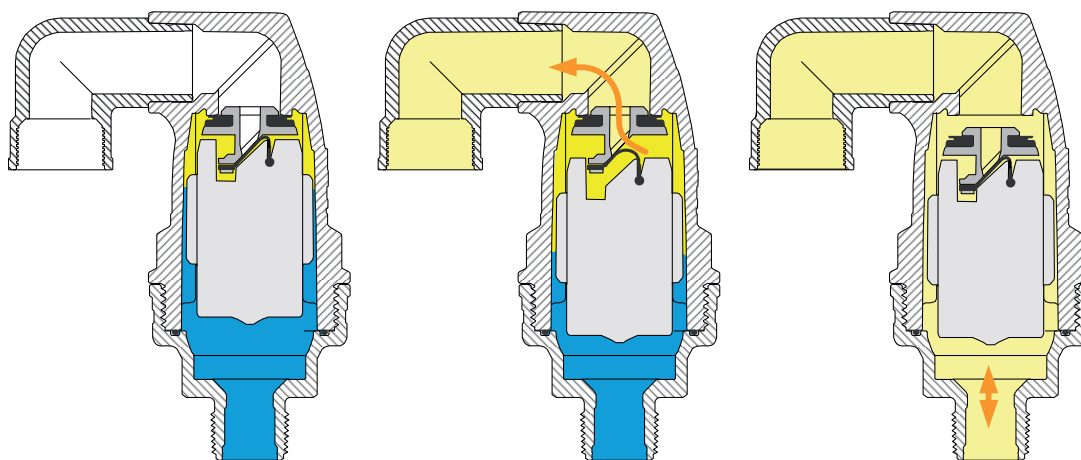

Pipe is full of water

Dissolved air is accumulated in the valve, released when the float drops down

Pipe is aerated

### Parts list and specifications:

Part	Description	Material
1	Body	Glass Reinforced Nylon Optional: Brass
2	Bonnet	Glass Reinforced Nylon
3	Float	Foamed Polypropylene
4	Slider	Glass Reinforced Nylon
5	Automatic Seal	Silicon
6	Kinetic Seal	EPDM Rubber
7	O ring	NBR
8	Drainage Elbow	Polypropylene

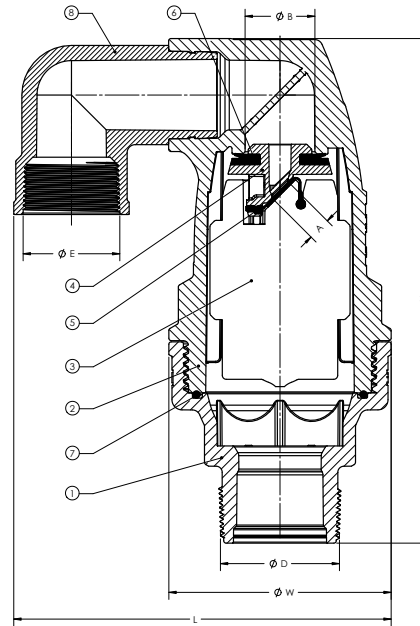

### Dimensions:

Valve	12 mm / 1/2"		20 mm / 3/4"		25 mm / 1"		50 mm / 2"	
	SI	US	SI	US	SI	US	SI	US
<b>H - Height</b>	183 mm	7 1/4"	183 mm	7 1/4"	183 mm	7 1/4"	249 mm	9 7/8"
<b>W - Width</b>	86 mm	3 1/3"	86 mm	3 1/3"	86 mm	3 1/3"	110 mm	4 1/3"
<b>D - Thread</b>	1/2" BSP	1/2" NPT	3/4" BSP	3/4" NPT	1" BSP	1" NPT	2" BSP	2" NPT
<b>A - Nozzle Area</b>	12.85 mm <sup>2</sup>	0.02 in <sup>2</sup>	12.85 mm <sup>2</sup>	0.02 in <sup>2</sup>	12.85 mm <sup>2</sup>	0.02 in <sup>2</sup>	12.85 mm <sup>2</sup>	0.02 in <sup>2</sup>
<b>K - Kinetic Nozzle Area</b>	314 mm <sup>2</sup>	0.49 in <sup>2</sup>	314 mm <sup>2</sup>	0.49 in <sup>2</sup>	314 mm <sup>2</sup>	0.49 in <sup>2</sup>	908 mm <sup>2</sup>	1.41 in <sup>2</sup>
<b>L - Total Width</b>	134 mm	5 1/4"	134 mm	5 1/4"	134 mm	5 1/4"	187 mm	7 3/8"
<b>E - Drainage Diameter</b>	3/4" BSP	3/4" BSP	3/4" BSP	3/4" BSP	3/4" BSP	3/4" BSP	1 1/2" BSP	1 1/2" BSP
<b>Weight</b>	470 g	1.04 lbs.	470 g	1.04 lbs.	470 g	1.04 lbs.	1052 g	2.32 lbs.

### Performance:

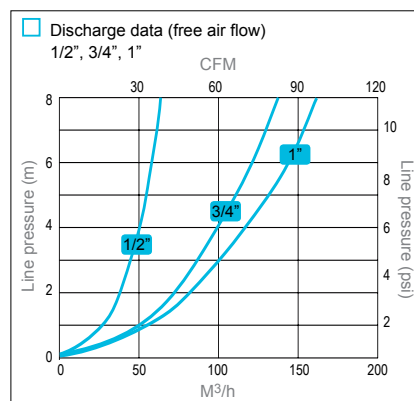
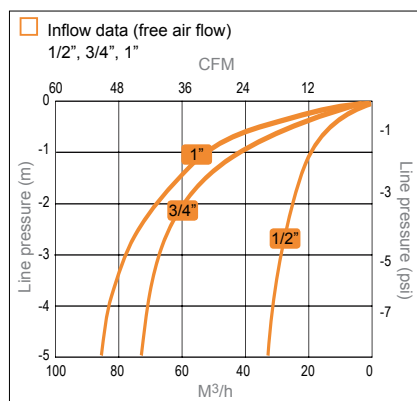
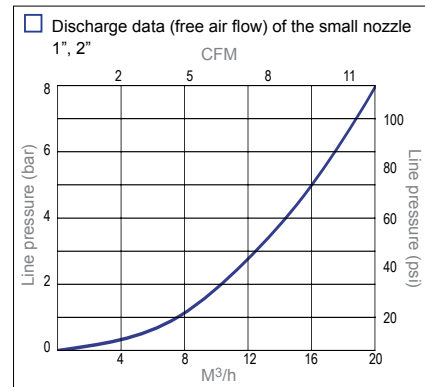
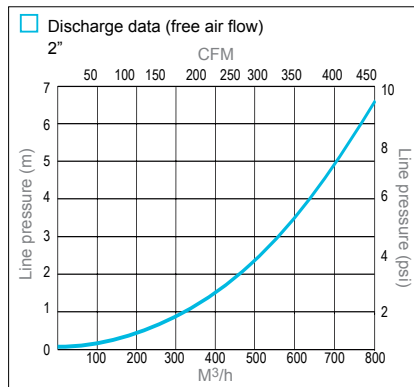
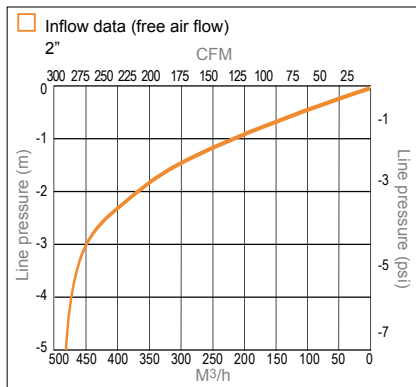

### Operating principle



#### Discharge of large volumes of air

During the pipe filling it is necessary to discharge air as water flows in. The air valve Max, thanks to the aerodynamic full port body, will make sure to avoid premature closures of the mobile block during this phase.

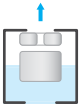

#### Air release during working conditions

During operation the air produced by the pipeline is accumulated in the upper part of the air valve. Little by little it is compressed and the pressure arrives to water pressure, therefore its volume increases pushing the water level downwards allowing the air release through the high capacity nozzle.

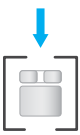

#### Entrance of large volumes of air

During pipeline draining, or pipe bursts, it is necessary to bring in as much air as the quantity of outflowing water to avoid negative pressure and serious damages to the pipeline, and to the entire system.

### Vacuum breaker version

To allow the entrance and discharge of large volumes of air only. This model is normally recommended in changes in slope ascending, long ascending segments, dry fire systems, and wherever the air release won't be required.

### Technical data

#### Working conditions

Treated water max. 60°C.  
Max. pressure 16 bar.  
Min. pressure 0,1 bar.

#### Valve selection

Body material: glass-reinforced PP.  
Inlet size: DN 25, DN 50 (1", 2").  
Connections: threaded male BSPT or NPT.  
Certified in compliance with EN-1074/4.

#### Nozzle specification

air valve size	kinetic orifice		autom. or.
	d (mm)	A (mm <sup>2</sup> )	A (mm <sup>2</sup> )
1"	21	346	5
2"	45	1590	12

### Air flow performance charts

AIR DISCHARGE DURING PIPE FILLING

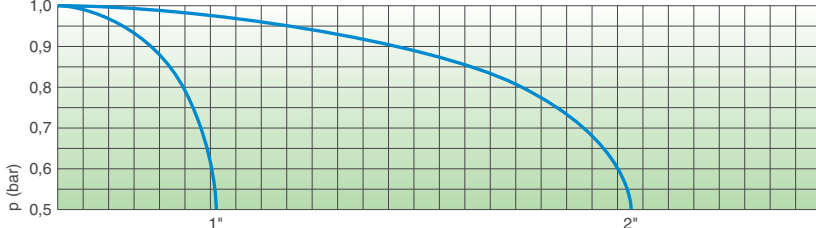
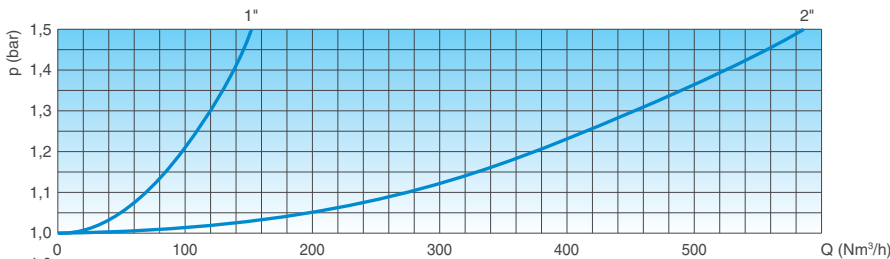

AIR ENTRANCE DURING PIPE DRAINING

AIR RELEASE DURING WORKING CONDITIONS

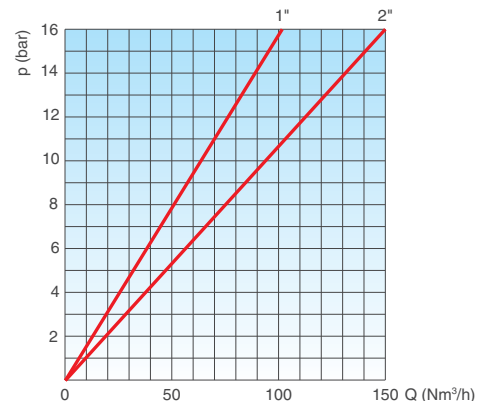

### Technical details

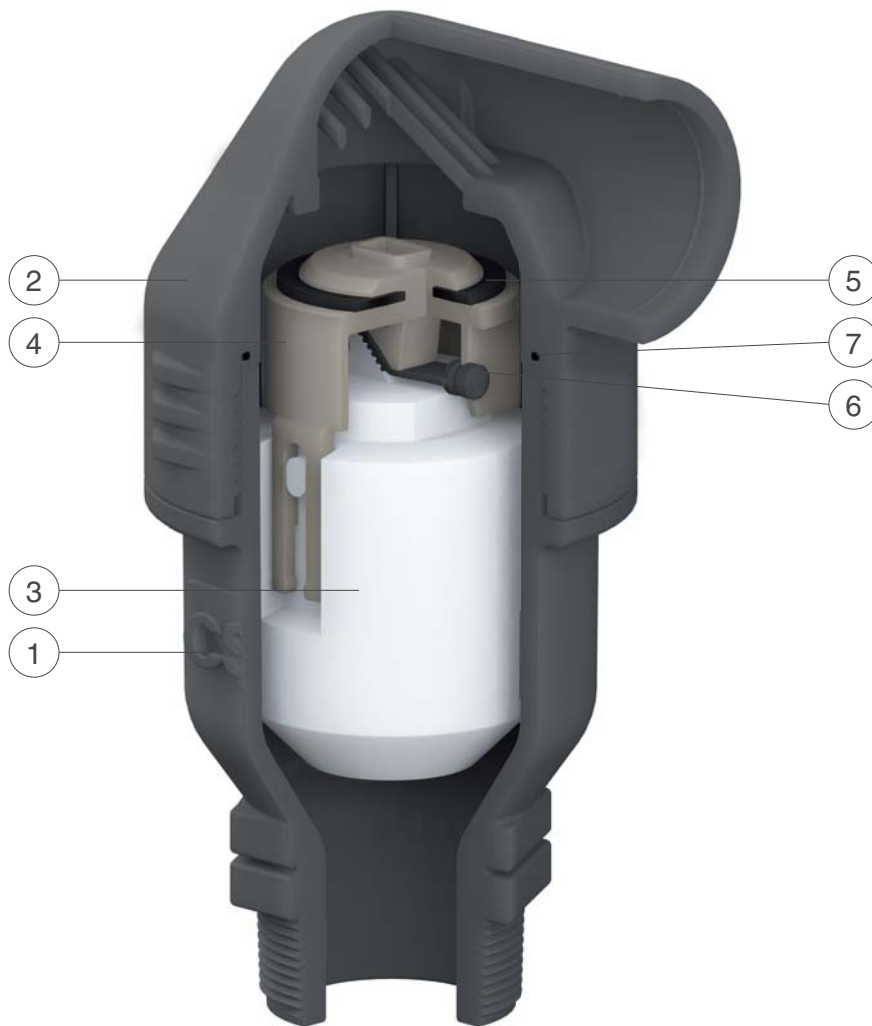

N.	Component	Material	Features
1	Body	glass reinforced polypropylene	provided with ribs for accurate guiding
2	Cap	glass reinforced polypropylene	provided with protection grid
3	Float	polypropylene	solid and resistant to high pressure
4	Kinetic plug	glass reinforced polypropylene	with high air release capacity
5	Kinetic orifice seal	EPDM	
6	Automatic orifice seal	EPDM	
7	O-ring	EPDM	

The list of materials and components is subject to changes without notice.

### Weights and dimensions

CONNECTION (E) inch	A mm	B mm	B mm	D mm	Weight Kg
Threaded 1"	80	174	92	CH 41	0,3
Threaded 2"	110	226	135	CH 65	0,75

All values are approximate, consult DNS service for more details.

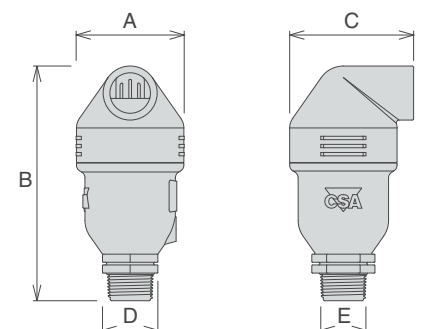



Designed Network Solutions

**Designed Network Solutions Ltd**

**15 Buckingham Drive**

**Northwich**

**CW9 8WB**

**E [craig@dns-uk-ltd.co.uk](mailto:craig@dns-uk-ltd.co.uk) T 07375 385089**