

Wastewater anti-shock combination air valve - Mod. SCF - AS

The SCF-AS guarantees the proper operation of pressurized sewage systems allowing the release of air pockets in working conditions, the entrance of large quantities of air in case of pipe bursting or draining operations and a controlled air outflow speed to minimize the risk of water hammer events.



Technical features and benefits

- Large lower body designed with strongly sloped funnel shaped walls to avoid deposit of grease or other material, and containing four ribs obtained by casting to guide the stainless steel float.
- Upper body containing a casing that protects the air release device against spurts during rapid filling.
- Mobile block including a large AISI 316 stainless steel float, placed on the lower body, and connected through a stainless steel rod to the air release system.
- Anti-Shock automatism composed of a metallic disk with 2 or more adjustable orifices, a guide bar and a counteracting spring in stainless steel.
- Drainage valve for chamber control and draining.
- Nozzle and gasket holder (patent pending) wear resistant thanks to gasket compression control.
- Maintenance can be easily performed from the top without removing the air valve from the pipe.

Applications

- To protect pumping stations and nodes of sewage main transmission lines exposed to water hammer and column separation in case of pump failure.
- Treatment plants subject to rapid changes of the flow rate.
- Whenever the technology of air valves for treated water can't be used and a protection against water hammer is needed.

Operating principle



Entrance of large volumes of air

During pipeline draining, or pipe bursts, it is necessary to bring in as much air as the quantity of outflowing liquid. This is to avoid negative pressure and serious damages to the pipeline and the entire system.



Controlled air discharge

During the air discharge it is necessary to avoid rapid closures of the mobile block, responsible of water hammer effects. The SCF AS will control the air outflow reducing the water approach velocity and thus minimizing the risk of overpressure.



Air release during working conditions

During operation the air produced by the pipeline is accumulated in the upper part. Little by little it is compressed and its volume increases, pushing the liquid level downwards and allowing the air release through the nozzle.

Optional



■ **Vacuum breaker version Mod. SCA**, to allow the entrance and the discharge of large volumes of air only with the anti-water hammer feature. This model is normally recommended at the pumps, on changes in slope ascending, long ascending segments exposed to transients events and, more in general, wherever air release won't be required still providing some protection against water hammer.



■ **Version for submerged applications SUB series**, standard for DN 50/65, available both for SCF AS and SCA Models, with elbow for air conveyance. The design sprang from the necessity of having an air valve performing also in case of flood, without the risk of contaminated water entering the pipeline. Another benefit of SUB is to avoid the spray effect, conveying spurts coming from the rapid closure of the air valve.

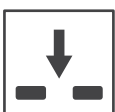

■ **Version for air entrance only IO series**, available for vacuum breaker model SCA. The most important application of IO is to allow the air valve installation in those locations of the system where, for project requirements, air discharge and release must be avoided.



■ The counteracting spring force as well as the sonic nozzles, both responsible of the proper operation of the AS device, can be adjusted on request according to the project conditions and the results of the transient analysis.

Technical data

Air valve selection chart

Air valve preliminary sizing as a function of pipeline internal diameter and fluid flow velocity expressed in m/s.

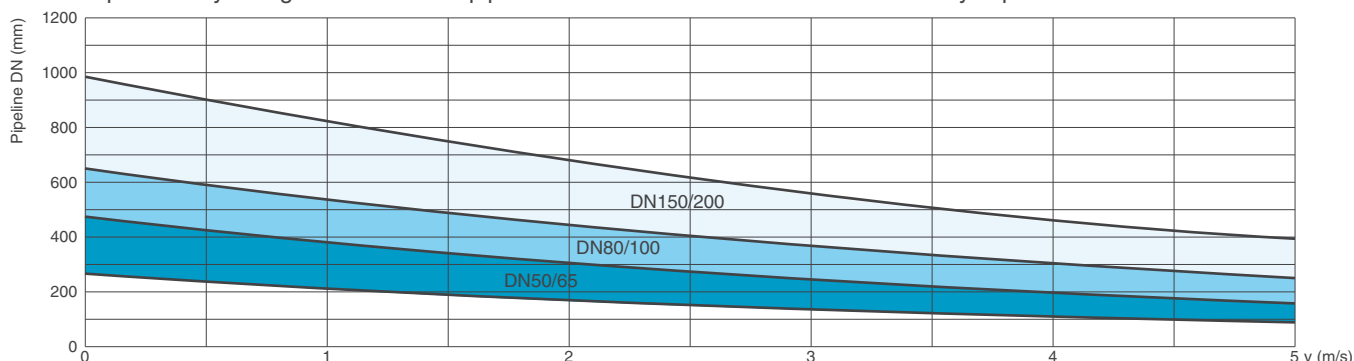

Air flow performance chart

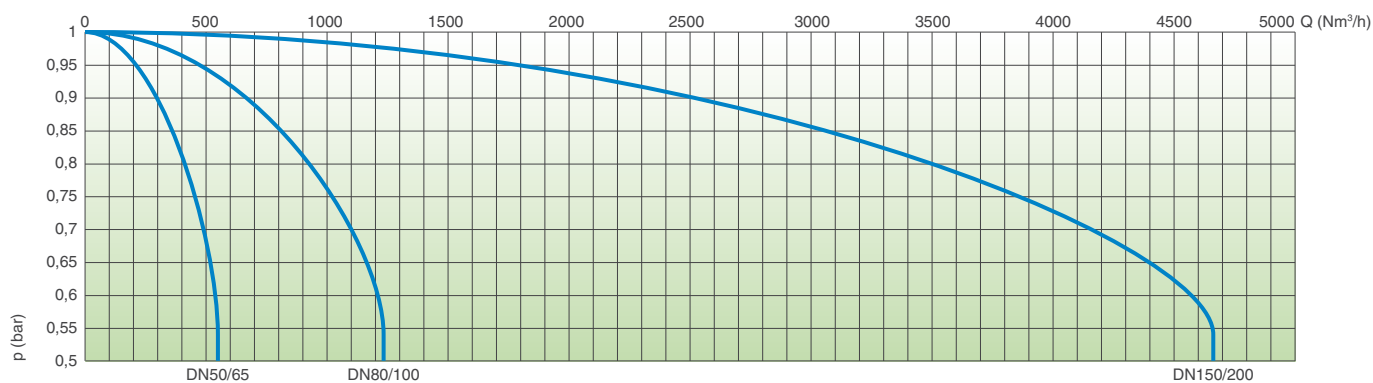

AIR ENTRANCE DURING PIPE DRAINING

The air flow charts were created in Kg/s from laboratory tests and numerical analysis, then converted in Nm³/h using a safety factor.

Working conditions

- Water and waste water max. 60°C.
- Maximum pressure 16 bar.
- Minimum pressure 0,2 bar. Lower on request.
- Higher temperatures on request.

Standard

- Certificated and tested in compliance with EN-1074/4.
- Flanges according to EN 1092/2.
- Epoxy painting applied through fluidized bed technology blue RAL 5005.
- Changes on the flanges and painting details available on request.

Nozzle choice

Nozzle diameter in mm according to the size of the air valve and the PN.

	PN 10	PN 16
DN 50/65	2,4	2,4
DN 80/100	3	3
DN 150/200	4	4

Weights and dimensions

DN mm	A mm	B mm	B' mm	C mm	D mm	Weight Kg
50/65	185	-	650	300	190	29
80/100	220	615	-	350	202	40
150	285	870	-	488	243	78
200	340	870	-	488	243	82

All values are approximate, consult DNS ltd service for more details.

AIR RELEASE DURING WORKING CONDITIONS

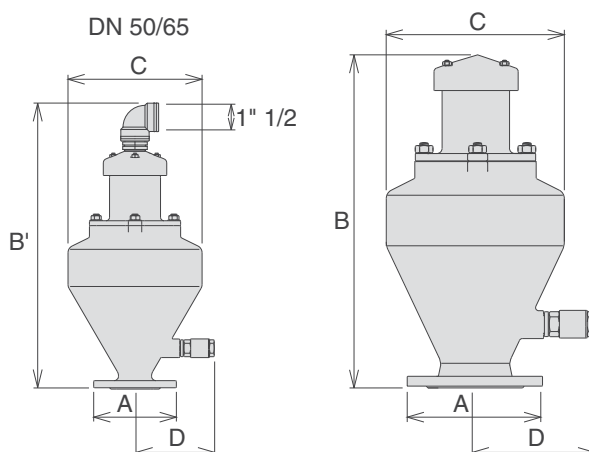
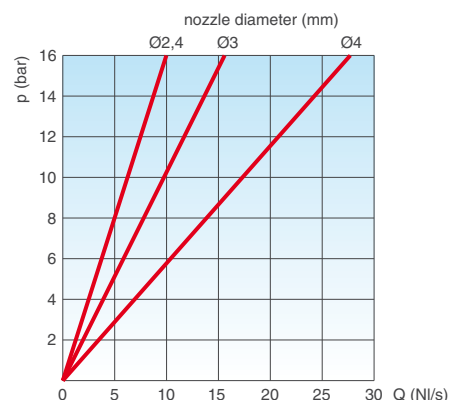

Technical details

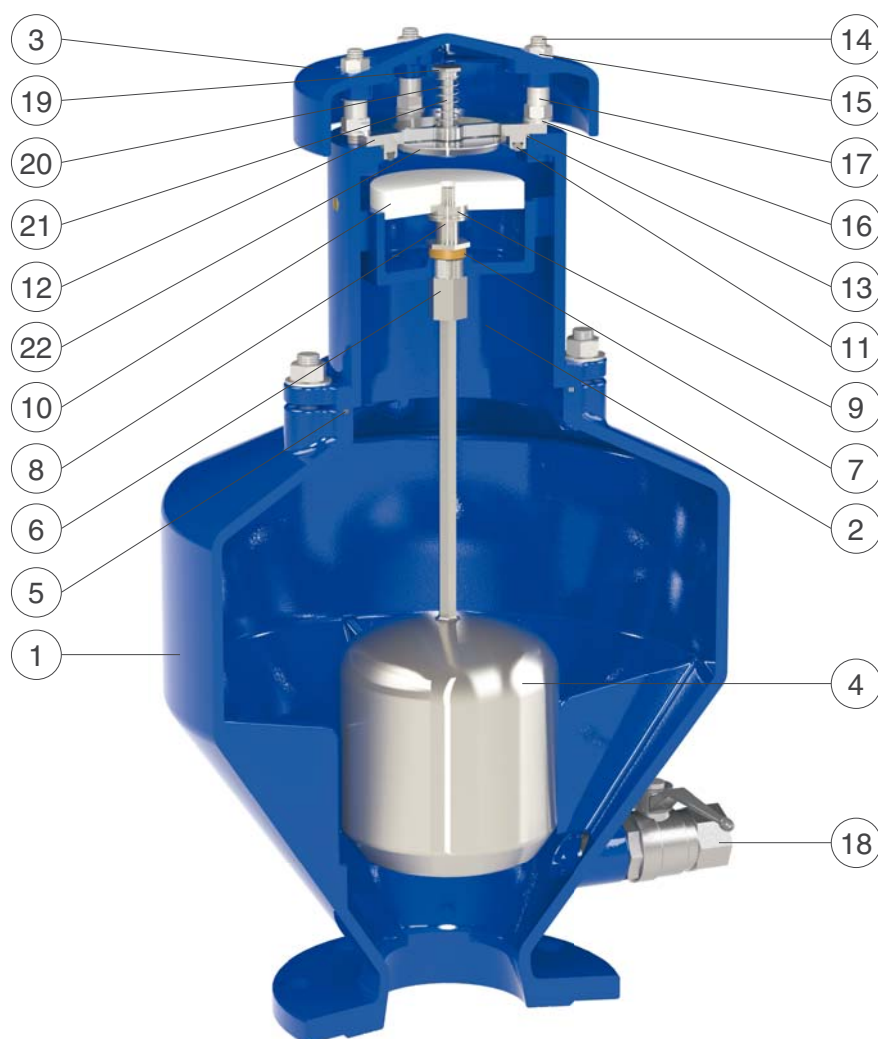

Threaded PP evacuation bend 1" 1/2 supplied as a standard for DN 50/65.

N.	Component	Standard material	Optional
1	Lower body	ductile cast iron GJS 500-7 or GJS 450-10	
2	Upper body	ductile cast iron GJS 500-7 or GJS 450-10	
3	Cap	ductile cast iron GJS 500-7 or GJS 450-10	
4	Float with shaft	stainless steel AISI 316	
5	O-ring	NBR	EPDM/Viton/silicone
6	Driving sleeve	stainless steel AISI 303	stainless steel AISI 316
7	Plane gasket	NBR	
8	Gasket holder	stainless steel AISI 316	
9	Nozzle subset	stainless steel AISI 316	
10	Obturator flat	polypropylene	
11	Seat gasket	NBR	EPDM/Viton/silicone
12	AS seat	stainless steel AISI 304	stainless steel AISI 316
13	O-ring	NBR	EPDM/Viton/silicone
14	Studs	stainless steel AISI 304	stainless steel AISI 316
15	Nuts	stainless steel AISI 304	stainless steel AISI 316
16	Washers	stainless steel AISI 304	stainless steel AISI 316
17	Spacers	stainless steel AISI 304	
18	Ball valve 1"	stainless steel AISI 316	
19	Spring guide nut (from DN 150)	stainless steel AISI 303	stainless steel AISI 316
20	Spring	stainless steel AISI 302	stainless steel AISI 316
21	AS shaft	stainless steel AISI 303	stainless steel AISI 316
22	AS flat	stainless steel AISI 304	stainless steel AISI 316

The list of materials and components is subject to changes without notice.