

# Anti-surge combination air valve DNS-TF-RFP-PN16-PAV

The DNS surge dampening, anti-slam automatic air valve DNS-TF-RFP-PN16-PAV has been designed to allow the release of air pockets accumulated in working conditions, the entrance of large volumes of air in case of pipe draining or bursts and to prevent pipeline damages coming from pressure transients, associated with high air outflow velocities.



## Technical features and benefits

- Uncontrolled pipeline filling operations and transient events will inevitably generate the rapid closure of the air valves installed along the system, with consequent damages. The DNS air valve 3F RFP will automatically adjust the outflow capacity, thus reducing the velocity of the incoming water column minimizing the risk of water hammer.
- The spray effect during closing and the risk of drowning, compared to standard combination air valves, are reduced.
- Single chamber full bore body in ductile cast iron, PN 40 bar rated, provided with internal ribs for accurate guiding of the mobile block.
- Mobile block composed of the main float and upper disk, joined together by the FCC air release system in AISI 316 (patent pending), and an additional anti surge obturator.
- Nozzle and gasket holder, part of DNS air release system, entirely made in AISI 316.
- Cover in ductile and screen in stainless steel as a standard execution, to prevent the entrance of insects, with optional outlet for submerged applications and air conveyance.

## Applications

- Main transmission lines.
- Water distribution networks.
- Irrigation systems.
- In general this model is used, in combination with DNS AS technology, on changes in slope and high points of the profile to provide the best air management and control with effective surge protection.

## Operating principle



### Discharge of large volumes of air

During the pipe filling it is necessary to discharge air as water flows in. The DNS 3F RFP, thanks to an aerodynamic full port body and deflector, will make sure to avoid premature closures of the mobile block during this phase.



### Controlled outflow

If the differential pressure of air, during pipe filling, increases above a certain value without control there is the risk of water hammer and damages to the system. Should that happen the RFP upper float will rise automatically, reducing the outflow and consequently the velocity of the approaching water column.



### Air release during working conditions

During operation the air produced by the pipeline is accumulated in the upper part of the air valve. Little by little it is compressed and the pressure arrives to water pressure, therefore its volume increases pushing the water level downwards allowing the air release through the nozzle.



### Entrance of large volumes of air

During pipeline draining, or pipe bursts, it is necessary to bring in as much air as the quantity of outflowing water to avoid negative pressure and serious damages to the pipeline, and to the entire system.

## Optional



■ **Vacuum breaker version DNS 2F RFP**, to allow the entrance of large volumes of air and the controlled outflow only. This model is normally recommended in changes in slope ascending, long ascending segments, dry fire systems, and wherever the water hammer effect has to be reduced without the necessity of air release.



■ **Version for submerged applications, SUB series**, available both for DNS 3F RFP and 2F RFP Models, with threaded elbow for air conveyance. The design sprang from the necessity of having an air valve performing also in case of flood, without the risk of contaminated water entering the pipeline. Another benefit of SUB is the possibility of conveying spurts coming from the closure away from the air valve.



■ **Version for air discharge only EO series**, available both for DNS 3F RFP and 2F RFP models. The most important application of EO is to allow the air valve installation in those locations of the system where HGL may drop below the pipe profile, and to any other node where for project requirements air entrance must be avoided, such as in pump suction lines or siphons pipelines.

## Technical data

### Air flow performance charts

AIR DISCHARGE DURING PIPE FILLING

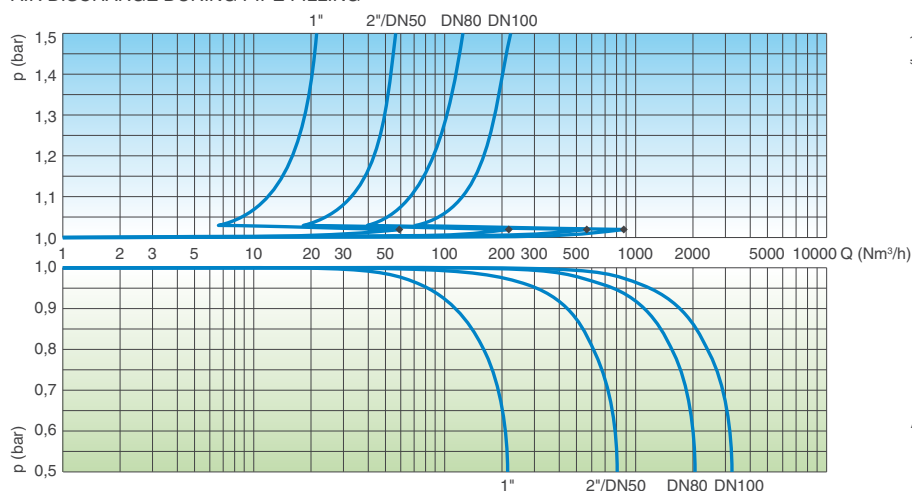

AIR ENTRANCE DURING PIPE DRAINING

AIR DISCHARGE DURING PIPE FILLING

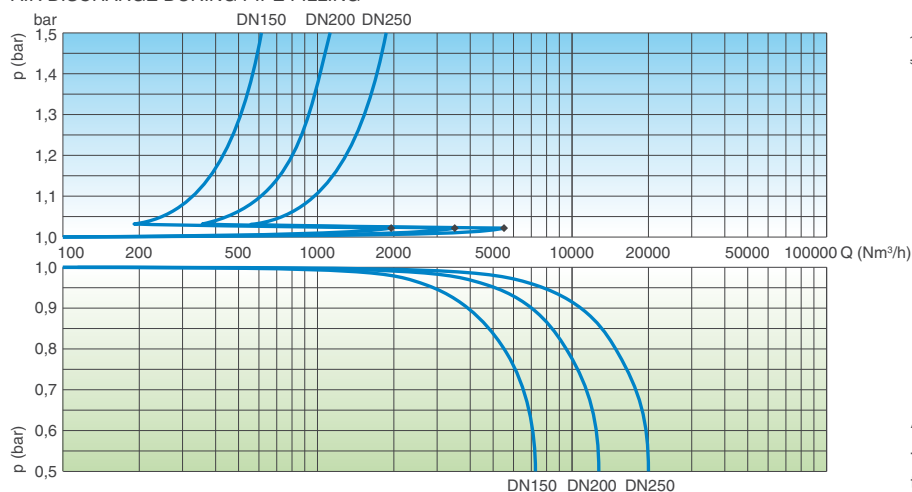

AIR ENTRANCE DURING PIPE DRAINING

### Working conditions

Treated water max. 60°C.

Max. pressure 40 bar.

Min. pressure 0,2 bar. Lower on request.

### Standard

Designed in compliance with EN-1074/4 and AWWA C-512. Flanges according to EN 1092/2 or ANSI 150. Epoxy painting applied through fluidized bed technology blue RAL 5005. Changes on the flanges and painting on request.

### Weights and dimensions

CONNECTION inch/mm	A mm	B mm	C mm		D mm	Weight Kg
Threaded 1"	117	240	-	-	CH 45	4,0
Threaded 2"	141	295	-	-	CH 70	7,5
Flanged 50	141	305	165	-	-	9,5
Flanged 80	172	322	210	205	-	13,8
Flanged 100	206	370	235	220	-	21,7
Flanged 150	285	555	305	285	-	44,5
Flanged 200	365	635	375	340	-	85,0
Flanged 250	450	785	450	405	-	134,0

All values are approximate, consult DNS service for more details.

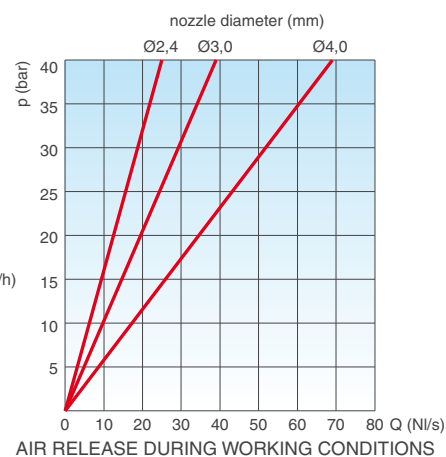
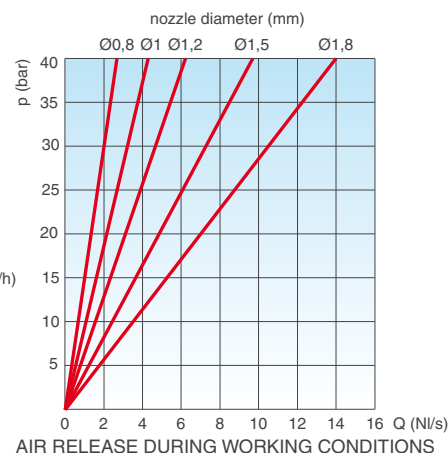

The air flow charts were created in Kg/s from laboratory tests and numerical analysis, without the screen, then converted in Nm³/h using a safety factor.

### Nozzle choice

Nozzle diameter in mm according to the size of the air valve and the PN.

	PN 10	PN 16	PN 25	PN 40
1"	1,5	1,2	1	0,8
2"/DN 50	1,8	1,5	1,2	1
DN 80	1,8	1,5	1,2	1
DN 100	3	2,4	1,8	1,2
DN 150	4	3	2,4	1,8
DN 200	4	4	4	3
DN 250	4	4	4	4

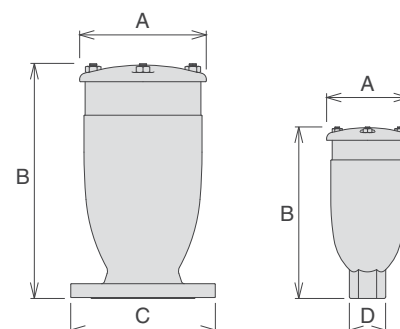

## Technical details

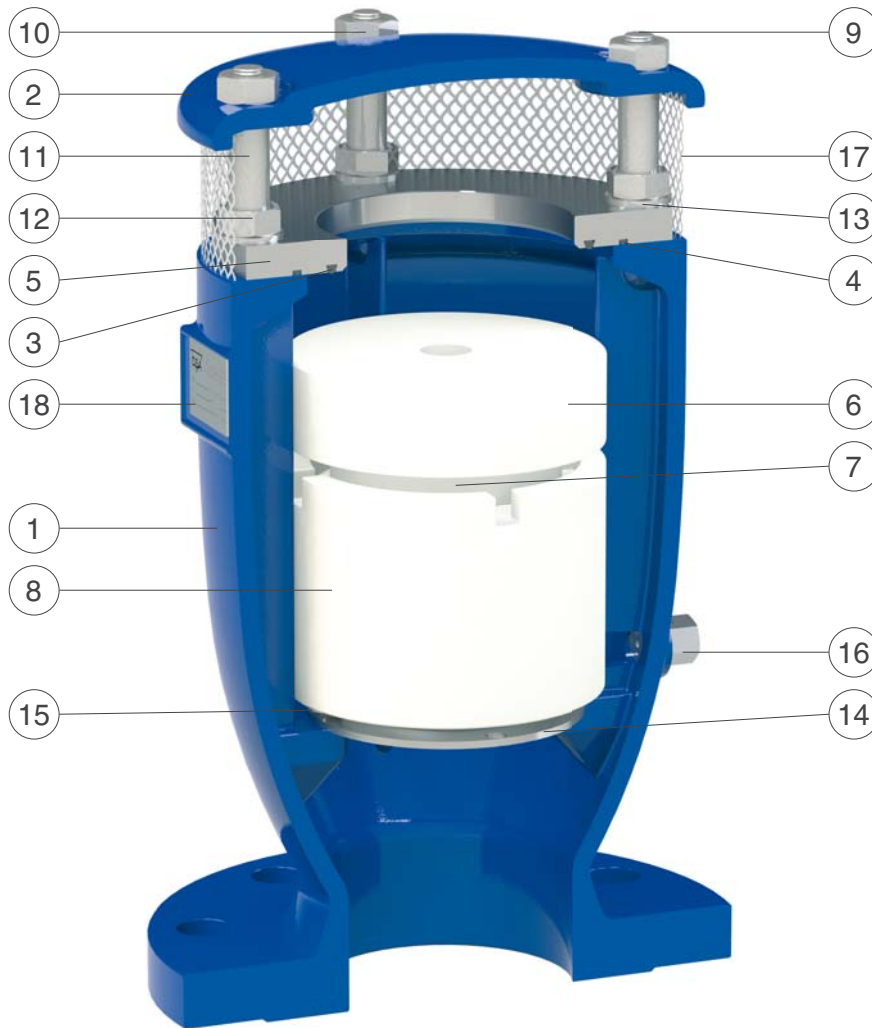

N.	Component	Standard material	Optional
1	Body	ductile cast iron GJS 500-7 or GJS 450-10	
2	Cap	ductile cast iron GJS 500-7 or GJS 450-10	
3	O-ring	NBR	EPDM/Viton/silicone
4	O-ring	NBR	EPDM/Viton/silicone
5	Seat	stainless steel AISI 304	stainless steel AISI 316
6	RFP flat with O-ring	polypropylene and NBR	EPDM/Viton/silicone
7	Upper flat with nozzle subset	polypropylene and stainless steel AISI 316	
8	Float	polypropylene	
9	Studs	stainless steel AISI 304	stainless steel AISI 316
10	Nuts	stainless steel AISI 304	stainless steel AISI 316
11	Spacers	stainless steel AISI 304	stainless steel AISI 316
12	Nuts	stainless steel AISI 304	stainless steel AISI 316
13	Washers	stainless steel AISI 304	stainless steel AISI 316
14	Deflector	stainless steel AISI 304	stainless steel AISI 316
15	Screws	stainless steel AISI 304	stainless steel AISI 316
16	Drain valve	stainless steel AISI 303	stainless steel AISI 316
17	Screen	stainless steel AISI 304	
18	Tag	stainless steel AISI 304	

The list of materials and components is subject to changes without notice.