



# Combination air valve DNS 3F

The DNS combination, triple function, automatic air valve DNS 3F will ensure the proper operation of the pipeline network allowing the release of air pockets during working conditions, the evacuation and entrance of large volumes of air during filling and draining operations.



## Technical features and benefits

- Single chamber full bore body in ductile cast iron, PN 40 bar rated, provided with internal ribs for accurate guiding of the floats.
- Aerodynamic deflector in stainless steel to avoid premature closures of the mobile block.
- Drainage valve, produced by DNS, for chamber control and pressure relief during maintenance.
- Mobile block composed of a cylindrical float and upper disk in solid polypropylene, joined together by the DNS air release system in AISI 316 (patent pending). The solid cylindrical floats, obtained by CNC machining, avoid deformations and ensure a great sliding precision inside the body processed ribs and a perfectly vertical thrust.
- Nozzle and gasket holder, part of DNS air release system, entirely made in stainless steel AISI 316 and designed with gasket compression control to prevent aging process and consequent leakage during working conditions.
- Maintenance can be easily performed from the top, without removing the air valve from the pipe.
- Cover in ductile and screen in stainless steel as a standard execution to prevent the entrance of insects, with three optional outlets (for submerged applications, air inlet only, air outlet only).

## Applications

- Main transmission lines.
- Water distribution networks.
- Irrigation systems.
- In general this model is used on changes in slope and at the high points of the pipeline.

## Operating principle



### Discharge of large volumes of air

During the pipe filling it is necessary to discharge air as water flows in. The DNS 3F, thanks to the aerodynamic full port body and deflector, will make sure to avoid premature closures of the mobile block during this phase.



### Air release during working conditions

During operation the air produced by the pipeline is accumulated in the upper part of the air valve. Little by little it is compressed and the pressure arrives to water pressure, therefore its volume increases pushing the water level downwards allowing the air release through the nozzle.



### Entrance of large volumes of air

During pipeline draining, or pipe bursts, it is necessary to bring in as much air as the quantity of outflowing water to avoid negative pressure and serious damages to the pipeline, and to the entire system.

## Optional



■ **Vacuum breaker version DNS 2F**, to allow the entrance and discharge of large volumes of air only. This model is normally recommended in changes in slope ascending, long ascending segments, dry fire systems, and wherever the air release won't be required.



■ **Version for submerged applications, SUB series**, available both for DNS 3F and 2F Models, with threaded elbow for air conveyance. The design sprang from the necessity of having an air valve performing also in case of flood, without the risk of contaminated water entering the pipeline. Another benefit of SUB is the possibility of conveying spurts coming from the rapid closure of the air valve.



■ **Version for air discharge only EO series**, available both for DNS 3F and 2F models. The most important application of EO is to allow the air valve installation in those locations of the system where HGL may drop below the pipe profile, and to any other node where for project requirements air entrance must be avoided, such as in pump suction lines or siphons pipelines.

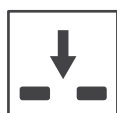

■ **Version for air entrance only IO series**, available for DNS 2F model only. The most important application of IO is to allow the air valve installation in those locations of the system where, for project requirements, air discharge and release must be avoided.

## Technical data

### Air flow performance charts

AIR DISCHARGE DURING PIPE FILLING

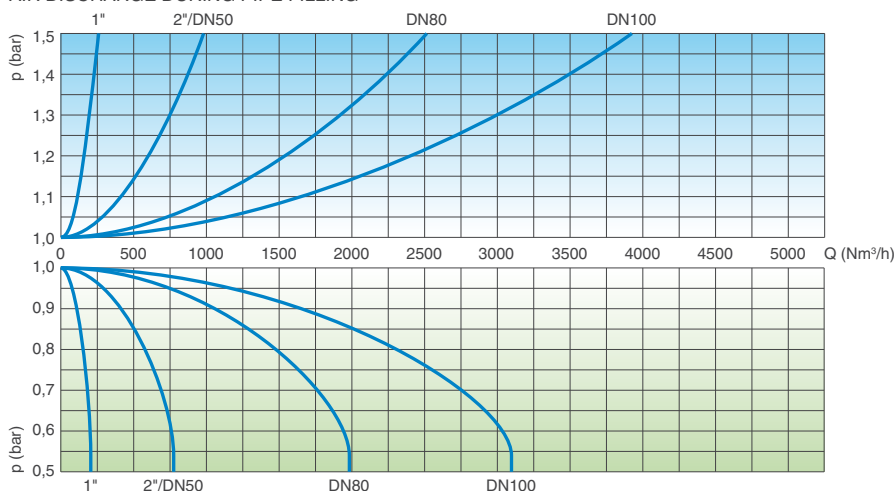

AIR ENTRANCE DURING PIPE DRAINING

AIR DISCHARGE DURING PIPE FILLING

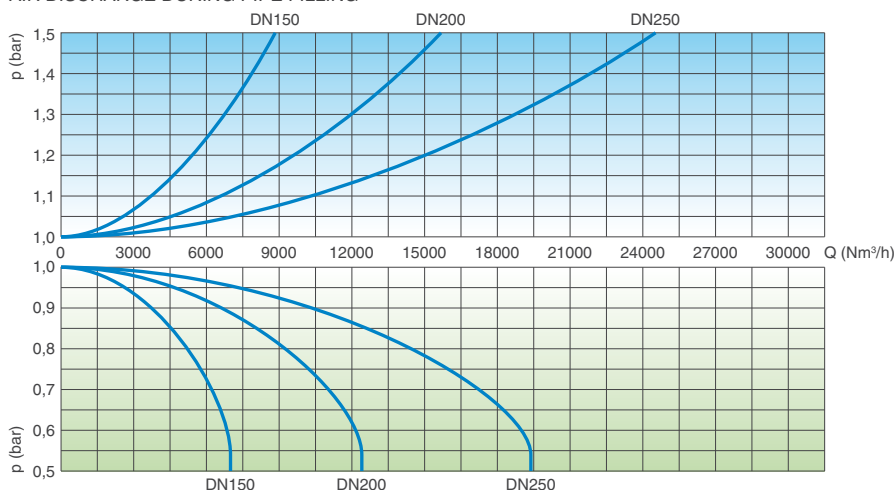

AIR ENTRANCE DURING PIPE DRAINING

### Working conditions

Treated water max. 60°C.

Max. pressure 40 bar.

Min. pressure 0,2 bar. Lower on request.

### Standard

Designed in compliance with EN-1074/4 and AWWA C-512. Flanges according to EN 1092/2 or ANSI 150. Epoxy painting applied through fluidized bed technology blue RAL 5005. Changes on the flanges and painting on request.

### Weights and dimensions

CONNECTION inch/mm	A mm	B mm	C mm		D mm	Weight Kg
Threaded 1"	117	240	-	-	CH 45	4,0
Threaded 2"	141	295	-	-	CH 70	7,5
Flanged 50	141	305	165	-	-	9,5
Flanged 80	172	322	210	205	-	13,8
Flanged 100	206	370	235	220	-	21,7
Flanged 150	285	555	305	285	-	44,5
Flanged 200	365	635	375	340	-	85,0
Flanged 250	450	785	450	405	-	134,0

All values are approximate, consult DNS service for more details.

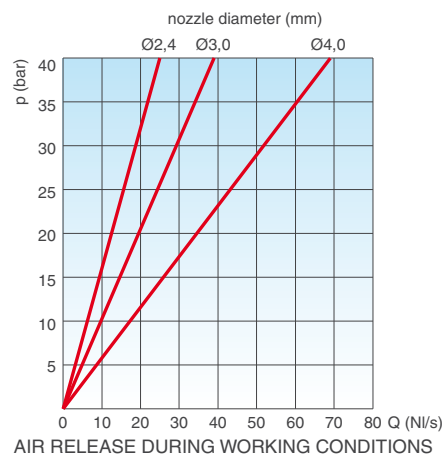
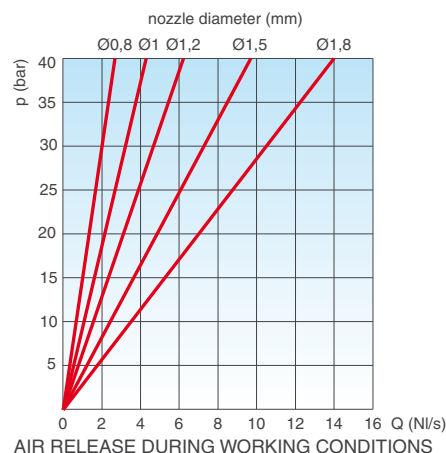

The air flow charts were created in Kg/s from laboratory tests and numerical analysis, without the screen, then converted in Nm³/h using a safety factor.

### Nozzle choice

Nozzle diameter in mm according to the size of the air valve and the PN.

	PN 10	PN 16	PN 25	PN 40
1"	1,2	1,2	1	0,8
2"/DN 50	1,5	1,2	1	0,8
DN 80	1,8	1,5	1,2	1
DN 100	2,4	1,8	1,8	1,2
DN 150	4	3	2,4	1,8
DN 200	4	4	4	3
DN 250	4	4	4	4

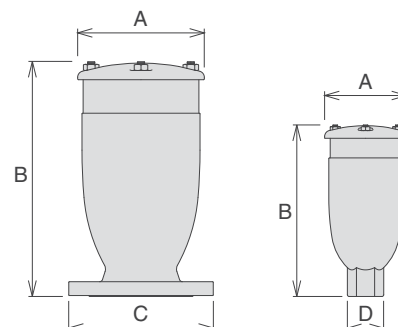

## Technical details

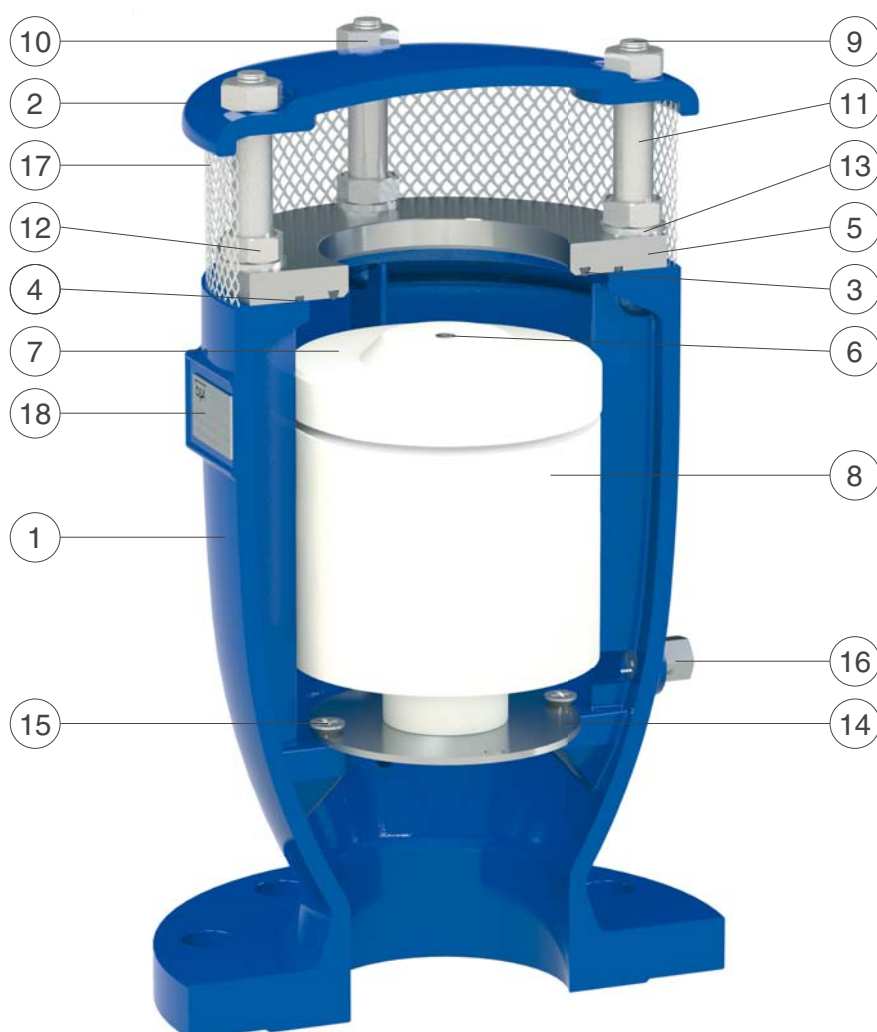

N.	Component	Standard material	Optional
1	Body	ductile cast iron GJS 500-7 or GJS 450-10	
2	Cap	ductile cast iron GJS 500-7 or GJS 450-10	
3	O-ring	NBR	EPDM/Viton/silicone
4	O-ring	NBR	EPDM/Viton/silicone
5	Seat	stainless steel AISI 304	stainless steel AISI 316
6	Nozzle Subset	stainless steel AISI 316	
7	Upper flat	polypropylene	
8	Float	polypropylene	
9	Studs	stainless steel AISI 304	stainless steel AISI 316
10	Nuts	stainless steel AISI 304	stainless steel AISI 316
11	Spacers	stainless steel AISI 304	stainless steel AISI 316
12	Nuts	stainless steel AISI 304	stainless steel AISI 316
13	Washers	stainless steel AISI 304	stainless steel AISI 316
14	Deflector	stainless steel AISI 304	stainless steel AISI 316
15	Screws	stainless steel AISI 304	stainless steel AISI 316
16	Drain valve	stainless steel AISI 303	stainless steel AISI 316
17	Screen	stainless steel AISI 304	
18	Tag	stainless steel AISI 304	

The list of materials and components is subject to changes without notice.



## FOX/LYNX air valves range vacuum breaker version

Designed to allow the discharge and entrance of large volumes of air during pipe filling and draining /bursts, this version is usually recommended in changes in slope ascending, long ascending segments, dry fire systems, and wherever the air release won't be required.

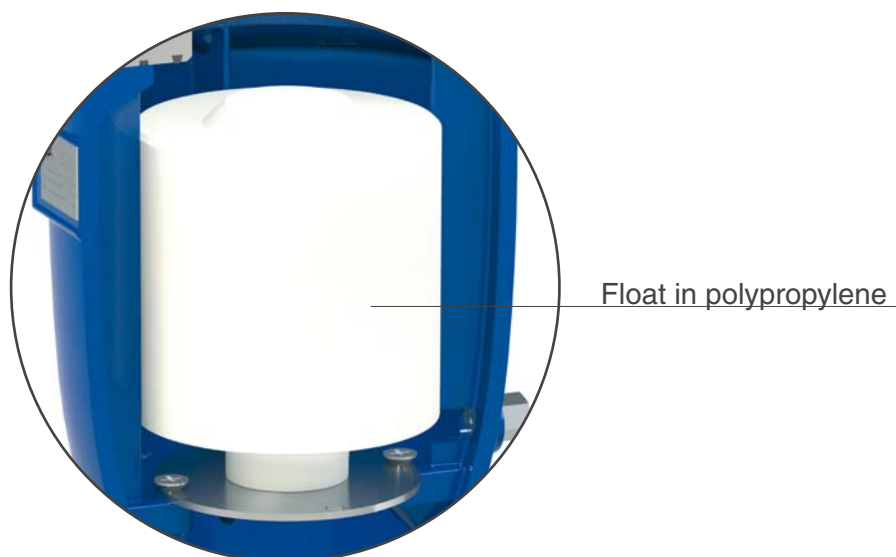

## FOX/LYNX Snorkel / Submergence kit - Mod. SUB

The air conveyance system SUB, provided with watertight threaded elbow for air conveyance and submerged applications, has been created to be retrofitted on existing FCC FOX air valves or as a stand-alone version. Another benefit of SUB is to convey spurts coming from the rapid closure of the air valve. The SUB kit is produced in plastic, different materials are available on request.

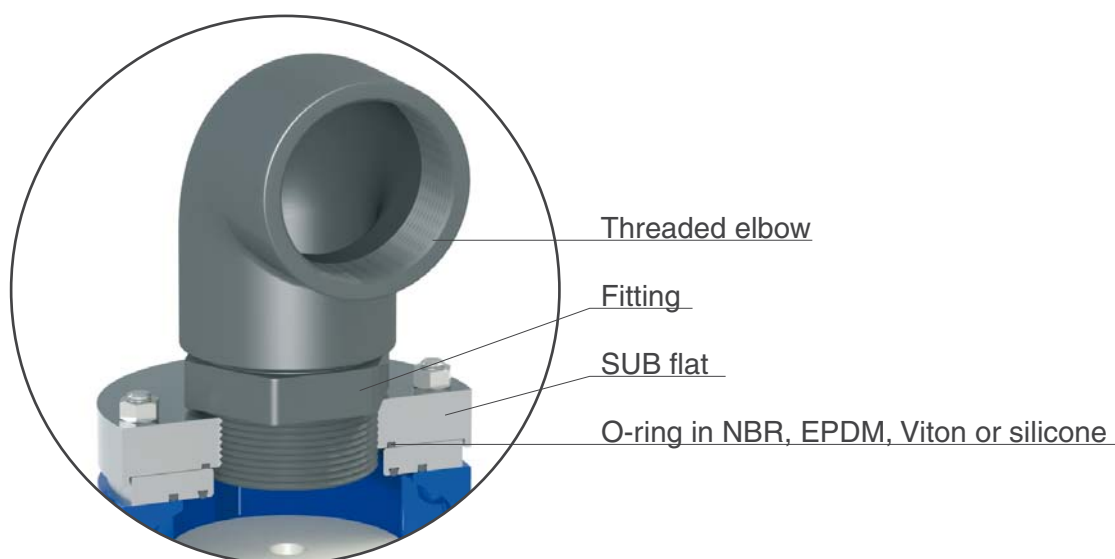



## FOX/LYNX air valves range discharge only kit EO

The most important application of EO is to allow the air valve installation in those locations of the system where HGL may drop below the pipe profile, and whenever for project requirements air entrance must be avoided.

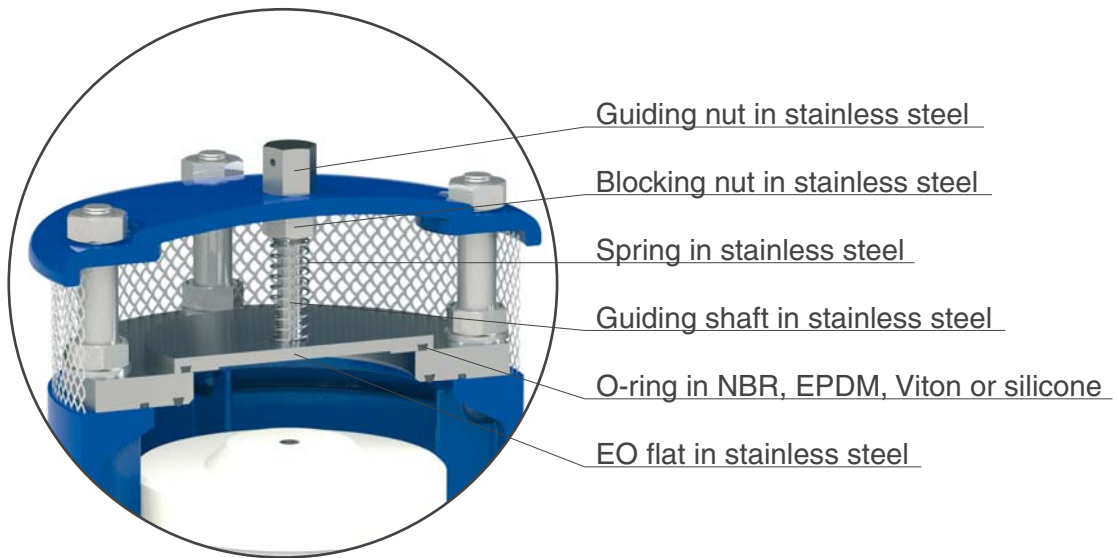

## FOX/LYNX air valves range entrance only kit IO

The most important application of IO is to allow the air valve installation in those locations of the system where, for project requirements, air discharge and release must be avoided.

