



Water combination underground air valve

The underground air valve has been designed to provide the proper solution for those locations requiring cost saving, frost protection, installation under roads, pavements, buildings. The air valve will ensure the operation of the pipeline networks allowing the release of air pockets during working conditions, the evacuation and the entrance of large volumes of air during filling and draining operations.



Technical features and benefits

- The design is to provide an alternative solution to conventional air valves installations avoiding chambers, structures, pits and sectioning devices between the air valve and the pipeline.
- Built in check valve for integral shut-off system when removing the air valve for maintenance purposes.
- Stand pipe in stainless steel for the maximum resistance against corrosion and to support the upper maneuvering system.
- Flanged basement to house the check valve and the drain port needed to avoid the accumulation of water inside the standpipe.
- Combination air valve FOX 3F automatically operated by the flow medium, and moving through the upper maneuvering system into a guidance bush with two O-rings for the perfect water tightness.
- Maintenance can be carried out from the top extracting the air valve from the standpipe.

Applications

- At high points and changes in slope of water distribution networks.
- Pressurized system with treated water.
- In areas exposed to frost, under the roads, buildings.

Operating principle

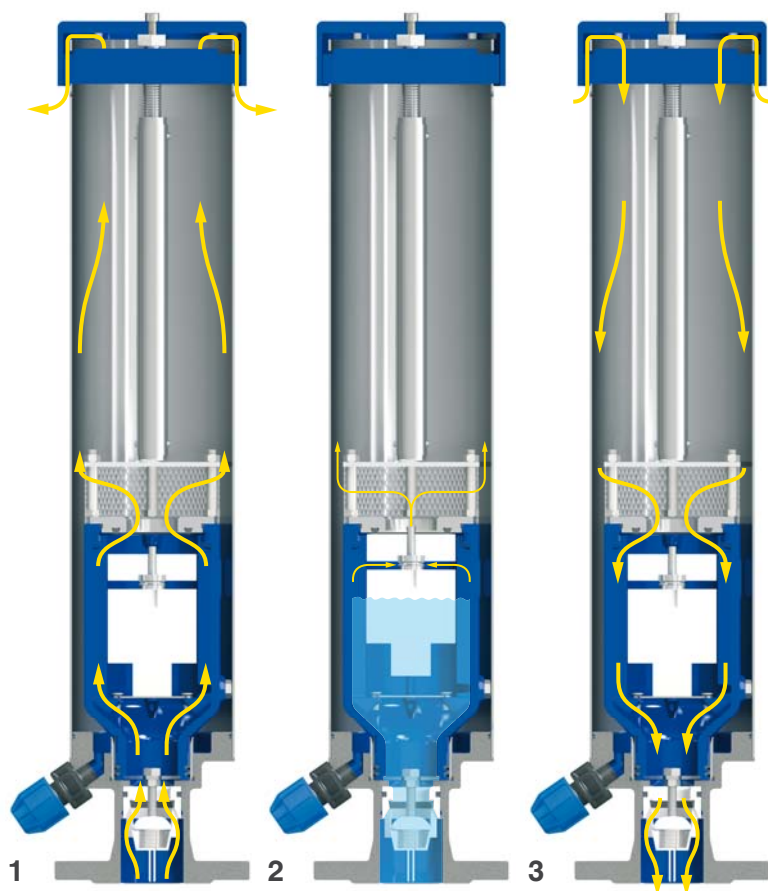

1. Discharge of large volumes of air

During the pipe filling it is necessary to discharge air as water flows in. The air valve, thanks to an aerodynamic body and internal deflector, will make sure to avoid premature closures of the mobile block during this phase.

2. Air release during working conditions

During operation the air produced by the pipeline is accumulated in the upper part of the air valve. Little by little it is compressed and the pressure arrives to water pressure, therefore its volume increases pushing the water level downwards allowing the air release through the nozzle.

3. Entrance of large volumes of air

During pipeline draining, or pipe bursts, it is necessary to bring in as much air as the quantity of outflowing water to avoid negative pressure and serious damages to the pipeline, and to the entire system.



Installation

The installation of this air valve simply requires a derivation from the main pipe, a manhole on top to allow for maintenance operations. The picture depicts the proper installation where the drain port plays a fundamental role, allowing for water discharge from the stand pipe. The drain should be located on a layer of gravel or crushed rock.

Air valve removal

The design of the underground air valve allows for a maintenance and replacement, without removing the air valve from the pipe, simply by acting on the cap and maneuvering key from above as shown on the picture on the right. All components will be pulled out from the top without the need of digging, and additional costs.

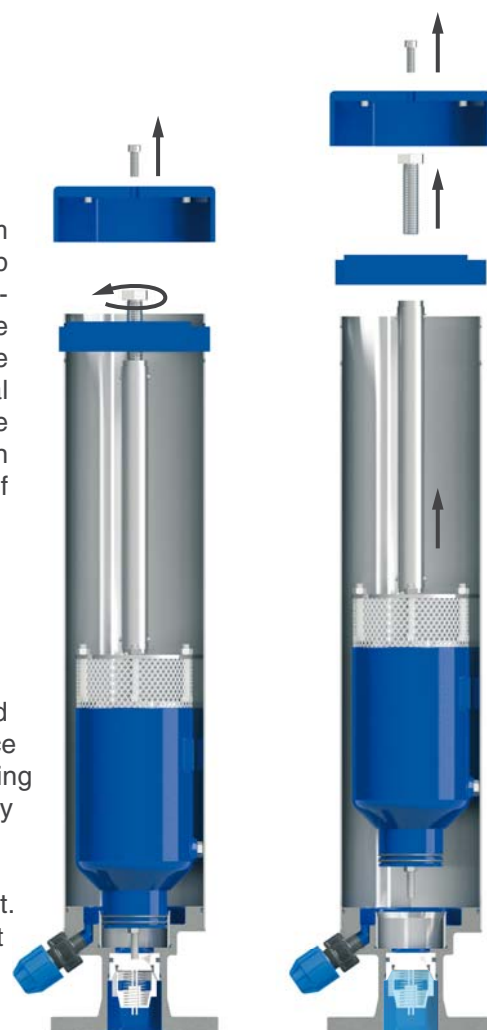

Technical data

Air flow performance charts

AIR DISCHARGE DURING PIPE FILLING

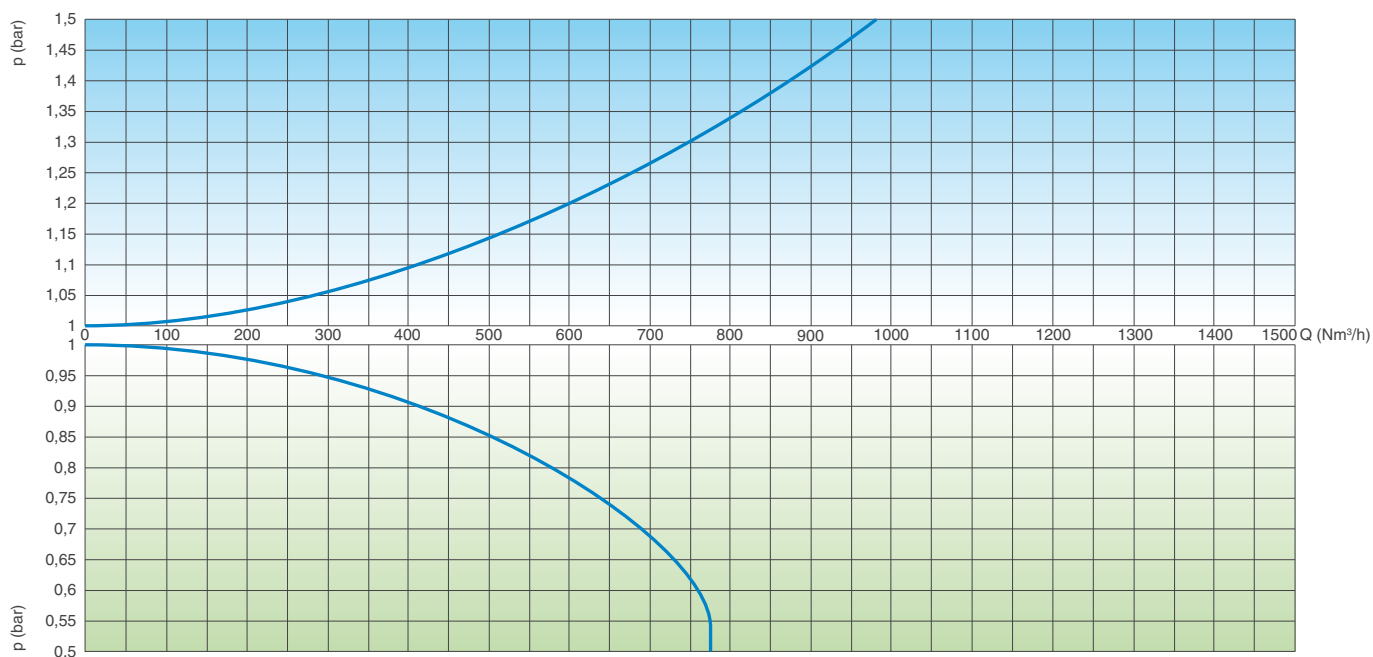

AIR ENTRANCE DURING PIPE DRAINING

The air flow charts were created in Kg/s from laboratory tests and numerical analysis without the screen, then converted in Nm³/h using a safety factor.

Working conditions

- Treated water max. 60° C.
- Higher temperatures on request.
- Maximum pressure 16 bar;
- Minimum pressure 0,2 bar. Lower on request.

Standard

- Designed in compliance with EN-1074/4.
- Flanges according to EN 1092/2.
- Epoxy painting applied through fluidized bed technology blue RAL 5005.
- Changes and variations on the flanges and painting details on request.

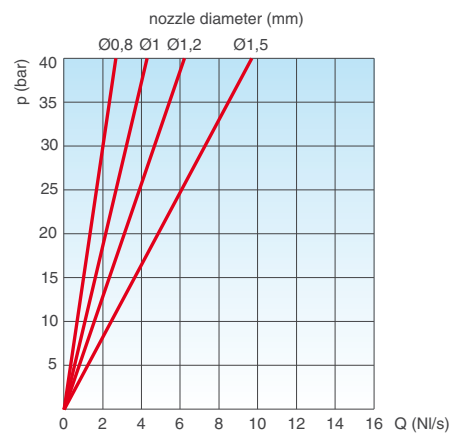

AIR RELEASE DURING WORKING CONDITIONS

Weights and dimensions

DN mm	A mm	B mm	C mm	D mm	Weight Kg
50	160	750	82,5	120	20,5
	160	1000	82,5	120	23,2
	160	1250	82,5	120	25,3
	160	1500	82,5	120	28,6
80	160	750	100	120	22,0
	160	1000	100	120	24,7
	160	1250	100	120	26,8
	160	1500	100	120	30,1

All values are approximate, consult DNS service for more details.

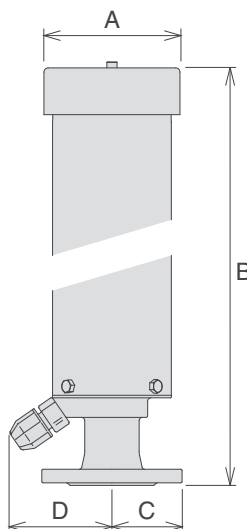

Nozzle choice

Nozzle diameter in mm according to the PN of the air valve.

PN 10	PN 16	PN 25	PN 40
1,5	1,2	1	0,8

Technical details

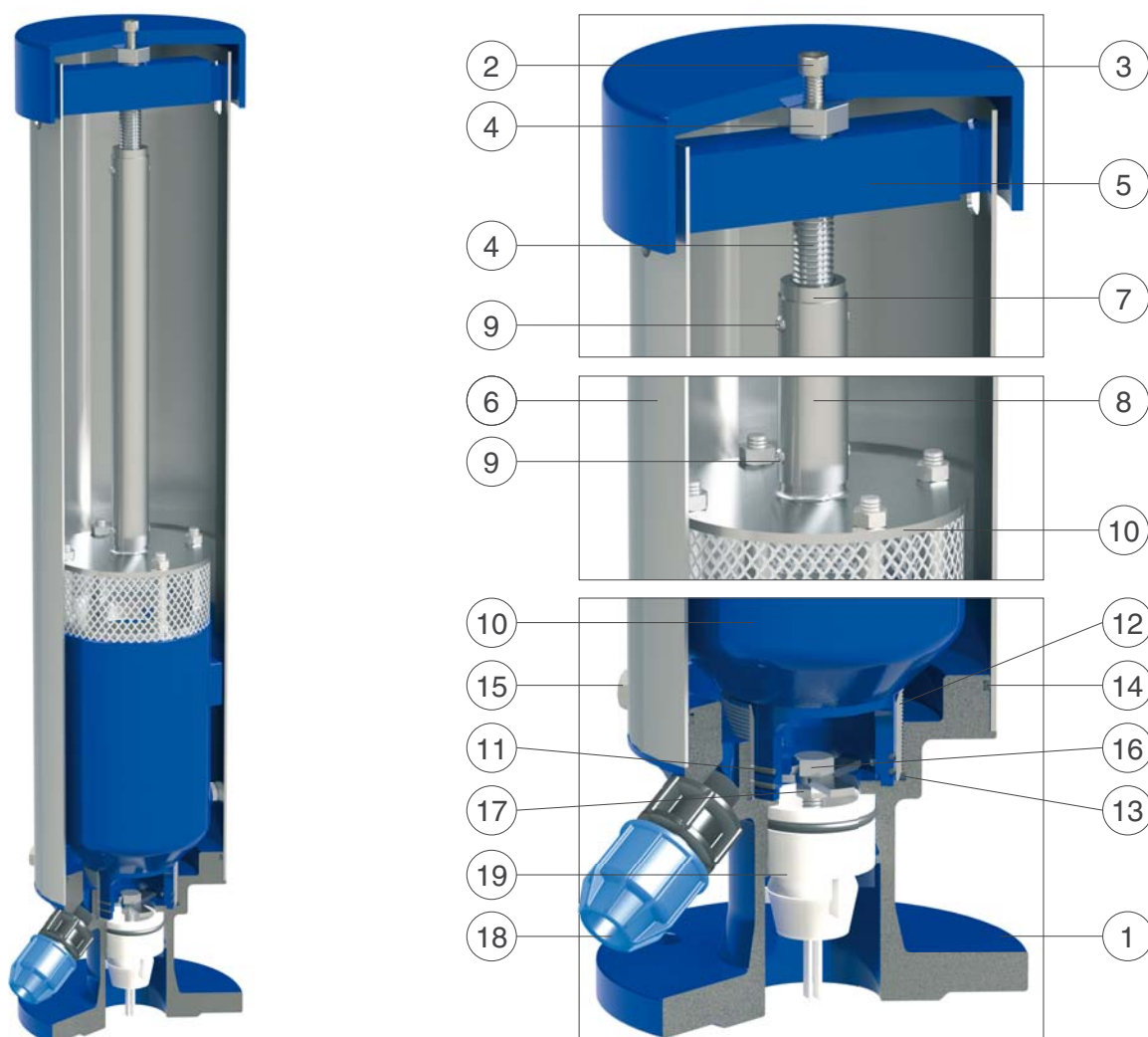

N.	Component	Standard material	Optional
1	Body	ductile cast iron GJS 500-7 or GJS 450-10	
2	Screw	stainless steel AISI 304	stainless steel AISI 316
3	Cap	painted aluminium S11	
4	Driving screw	stainless steel AISI 304	
5	Guiding plate	painted steel	
6	Stand pipe	stainless steel AISI 304	
7	Screw housing	stainless steel AISI 303	
8	Maneuvering pipe	stainless steel AISI 304	
9	Plug	stainless steel AISI 304	
10	FOX 2"	in different executions (see FOX technical details)	
11	O-ring	NBR	EPDM/Viton/silicone
12	Threaded sleeve	stainless steel AISI 304	
13	O-ring	NBR	EPDM/Viton/silicone
14	O-ring	NBR	EPDM/Viton/silicone
15	Screws	stainless steel AISI 304	stainless steel AISI 316
16	Opening screw	stainless steel AISI 304	stainless steel AISI 316
17	Locking nut	stainless steel AISI 304	stainless steel AISI 316
18	Drainage	polypropylene	
19	Check valve	Delrin (polyoxymethylene)	

The list of materials and components is subject to changes without notice.